

APV Puma Pump Series V & VI

Exploded View - Shrouded Pump (Series V & VI)

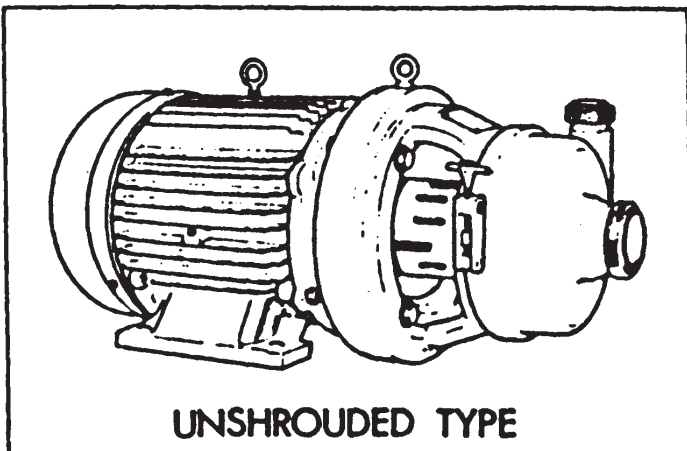

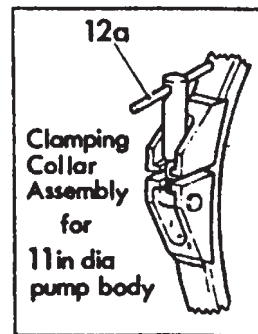
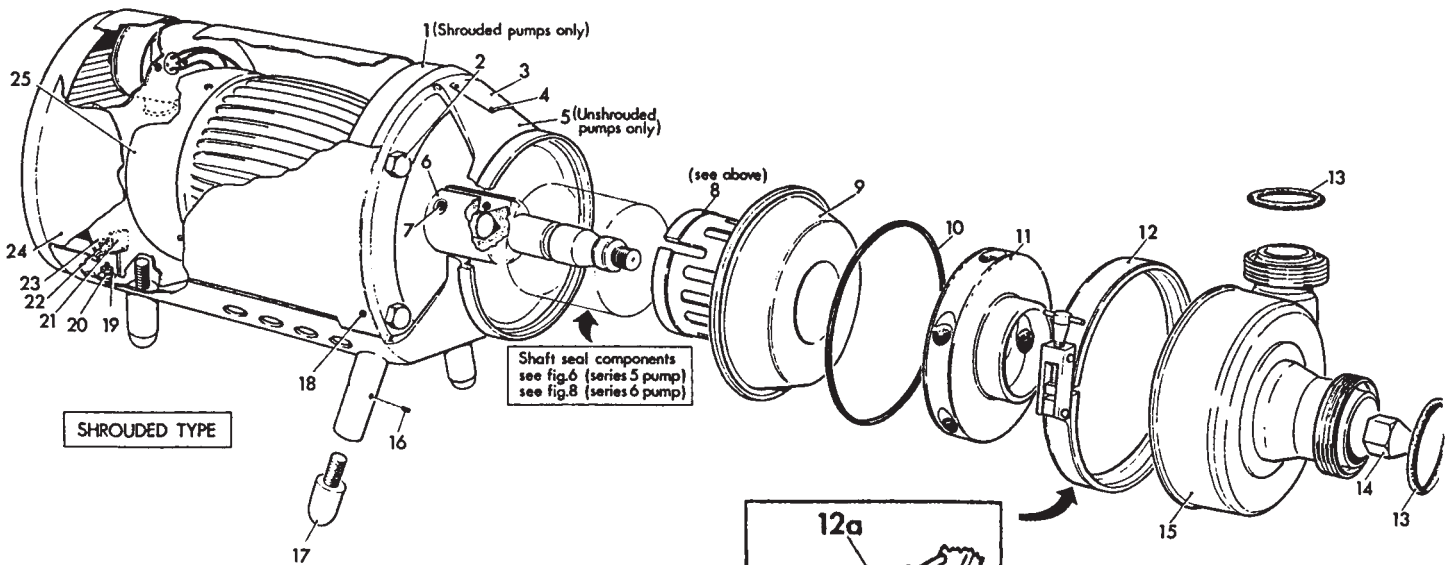
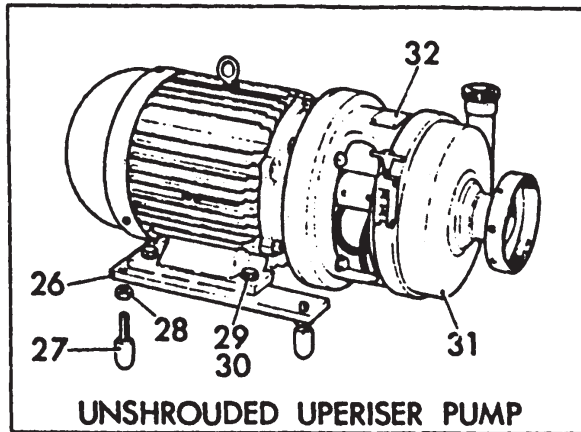
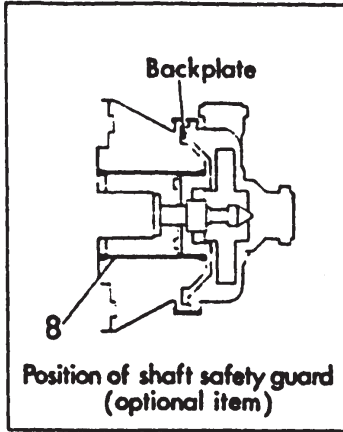

Puma Pump Series V & VI (contd)

PUMA PUMP SERIES V & VI - INCLUDING 1 1/2/ 7 PUMP, SERIES 2								
ITEM	DESCRIPTION	No. off	1 1/2/7	2/2/9	2/2 1/2/9	2/3/9	2/3/11	3/4/11
Page 12								
1	Main supporting frame and cradle: 1.1 kW shrouded motor 2.2 kW shrouded motor 4.0 kW shrouded motor 5.5 kW shrouded motor	1	206513 - - -	- 206552 206554 -	- 206552 206554 -	- 206552 206554 -	- - 206558 206560	- - - -
2	Setscrews for above frame, Hex. hd. 1.1 kW motor size 2.2 kW motor size Larger sizes	4	431635 - -	- 431645 431666	- 431645 431666	- 431645 431666	- - 431666	- - -
	Nut, hexagon, for above	†† 4	417864 - -	- 417865 417867	- 417865 417867	- 417865 -	- - -	- - -
3	Nameplate in English in German	1	457841 457843	457841 457843	457841 457843	457841 457843	457841 457843	457841 457843
4	Pin, rd.hd. No.4, for above	4	434261	434261	434261	434261	434261	434261
5	Extension frame for unshrouded motors	1	321976	-	-	322001	322002	322002
2	Setscrew for above frame, hex. hd.	4	431635 - -	- - -	- - -	- - 460158	- - 460158	- - 460158
	Nut, hexagon, for above	†† 4	417864 - -	- - -	- - -	- - 460212	- - 460212	- - 460212
	Washer	†† 4	- - -	443518 443520 -	443518 443520 -	443518 443520 460317	- 443520 460317	- - 460317
6	Shaft, stub 1 in. dia. 1.1 kW motor 2.2 kW motor 4.0 kW motor 5.5 & 7.5 kW motor 1 1/2 in. dia. for larger motors	1	354347 - - - -	- 354341 354342 -	- 354341 354342 354343	- 354341 354342 354343 354339	- - 354342 354343	- - - 354339 354339
7	Screw, cap, socket head 1/4 in. B.S.F. 5/16 in. B.S.F. 3/8 in. B.S.F.	2	445244 - -	445244 - -	445244 445245 -	445244 445245 445247	445244 445245 445247	- - 445247
8	Safety guard, stub shaft 1.1 kW unshrouded motor 1.1 kW shrouded motor 2.2 kW shrouded motor 4.0 kW shrouded motor 5.5 & 7.5 kW shrouded motors 11, 15 & 18.5 kW unshrouded motors	W.O	231132 231125 - - -	- - 231126 231127 -	- - 231126 231127 231128	- - 231126 231127 231128 231131	- - - 231127 231128 231131	- - - - - 231131
9	Backplate 1 in. dia. pump shaft 1 1/2 in. dia. pump shaft	1	341365 -	338815 -	338815 -	338815 336469	338816 336470	- 336470
10	Joint, body	1	413859	413800	413800	413800	413858	413858
11	Impeller for 1 in. dia. pump shaft without balancing holes Size 3 1/2 in. (89 mm) Size 3 3/4 in. (95 mm) Size 4 in. (102 mm) Size 4 3/8 in. (111 mm)	1	325802 325803 325804 325805	- - - -	- - - -	- - - -	- - - -	- - - -

†† not illustrated



PUMA PUMP SERIES V & VI - INCLUDING 1 1/2/ 7 PUMP, SERIES 2								
ITEM	DESCRIPTION	No. off	1 1/2/2/7	2/2/9	2/2 1/2/9	2/3/9	2/3/11	3/4/11
11 (cont)	Size 4 7/8 in. (124 mm)		325806	-	-	-	-	-
	Size 5 1/4 in. (133 mm)		325807	-	-	-	-	-
	Size 5 in. (127 mm)		-	-	-	326088	-	-
	Size 5 1/2 in. (140 mm)		-	-	-	326087	-	-
	Size 6 in. (152 mm)		-	-	-	326086	-	-
	Size 6 1/2 in. (165 mm)		-	-	-	326085	-	-
	Size 7 in. (178 mm)		-	-	-	326084	-	-
	Size 7 1/2 in. (191 mm)		-	-	-	326083	326083	-
	Size 8 in. (203 mm)		-	-	-	-	325817	-
	Size 8 1/2 in. (216 mm)		-	-	-	-	325818	-
	Size 9 in. (229 mm)		-	-	-	-	325819	-
	Size 9 1/2 in. (241 mm)		-	-	-	-	325820	-
	for 1 in. dia. pump shaft with balancing holes							
	Size 5 in.		-	326039	326039	326094	-	-
	Size 5 1/2 in.		-	326038	326038	326093	-	-
	Size 6 in.		-	326037	326037	326092	-	-
	Size 6 1/2 in.		-	326036	326036	326091	-	-
	Size 7 in.		-	326035	326035	326090	-	-
	Size 7 1/2 in.		-	326034	326034	326089	326089	-
	Size 8 in.		-	-	-	325821	325821	-
	Size 8 1/2 in.		-	-	-	325822	325822	-
	Size 9 in.		-	-	-	325823	325823	-
	Size 9 1/2 in.		-	-	-	325824	325824	-
	for 1 1/2 in. dia. pump shaft without balancing holes							
	Size 5 in.		-	-	-	325891	-	-
	Size 5 1/2 in.		-	-	-	325892	-	-
	Size 6 in.		-	-	-	325893	-	-
	Size 6 1/2 in.		-	-	-	325894	-	-
	Size 7 in.		-	-	-	325895	-	-
	Size 7 1/2 in.		-	-	-	325896	325896	-
	Size 8 in.		-	-	-	-	325706	-
	Size 9 in.		-	-	-	-	325708	-
	Size 9 1/2 in.		-	-	-	-	325709	-
	for 1 1/2 in. dia. pump shaft with balancing holes							
	Size 5 in.		-	-	-	325700	-	-
	Size 5 1/2 in.		-	-	-	325701	-	-
	Size 6 in.		-	-	-	325702	-	-
	Size 6 1/2 in.		-	-	-	325703	-	-
	Size 7 in.		-	-	-	325704	-	325898
	Size 7 1/2 in.		-	-	-	325705	325705	-
	Size 8 in.		-	-	-	-	325711	-
	Size 8 1/2 in.		-	-	-	-	325712	-
	Size 9 in.		-	-	-	-	325713	-
	Size 9 1/2 in.		-	-	-	-	325714	-
12	Clamping collar assembly	1	228719	228717	228717	228717	228721	228721
12A	Tommy bar for clamping collar	1	-	-	-	-	304079	304079
13	Ring, joint, RJT	As reqd						
	Size 1 1/2 in.		413509	-	-	-	-	-
	Size 2 in.		413510	413510	413510	413510	413510	-
	Size 2 1/2 in.		-	-	413512	-	-	-
	Size 3 in.		-	-	-	413514	413514	-
	Size 4 in.		-	-	-	-	-	413517
14	Nut, impeller	1						
	1 in. dia pump shaft		334736	335750	335750	335750	-	-
	1 1/2 in. dia pump shaft		-	-	-	335745	335745	335745

†† not illustrated



Puma Pump Series V & VI (contd)

PUMA PUMP SERIES V & VI - INCLUDING 1 ¹ / ₂ /2/ 7 PUMP, SERIES 2								
ITEM	DESCRIPTION	No. off	1 ¹ / ₂ /2/7	2/2/9	2/2 ¹ / ₂ /9	2/3/9	2/3/11	3/4/11
15	Body, pump RJT connections ISS connections FOR SHROUDED MOTORS ONLY:	1	225568 225569	200763 200764	200769 200770	200798 200799	207100 207101	207673 207674
16	Grubscrew 2BA, slot head	3	434106	434110	434110	434110	434110	-
17	Foot, ball	3	337659	337600	337600	337600	337600	-
18	Setscrew, 2BA, round head	1 or 2	432410	432410	432410	432410	432410	-
19	Washer, plain, 1/4 in.	1	443816	443816	443816	443816	443816	-
20	Bolt, hex. head, 1/4 in. B.S.W.	1	431625	431625	431625	431625	431625	-
21	Clip	2	314254	314253	314253	314253	314253	-
22	Screw, OBA, cheese head 2BA, cheese head	2 2	254111 -	- 452601	- 452601	- 452601	- 452601	- -
23	Baffle plate and terminal box assembly	1	228537	228543	228543	228543	228543	-
	Earth cable	††	442010	442011	442011	442011	442011	-
	Grommet	††	410500	410500	410500	410500	410500	-
24	Shroud, case assembly	1	227418	227417	227417	227417	227417	-
	Eyebolt, for unshrouded motors only	††	-	-	-	402358	402358	402358
25	Motor, electric, 3 ph. 50 Hz Shrouded pumps: 1.1 kW 220/380-420 V 2.2 kW 220/380-420 V 4.0 kW 380-420 V 5.5 kW 380-420 V 7.5 kW 380-420 V Unshrouded pumps: 1.1 kW 220/380-420 V 11.0 kW 380-420 V 15.0 kW 380-420 V 18.5 kW 380-420 V	1	415732 - - - - - 415734 - - - -	- 457132 457103 - - - - - - - -	- 457132 457103 457105 457107 - - - - - -	- 457132 457103 457105 457107 - - 416672 416673 - -	- - 457103 457105 457107 - - 416672 416673 - -	- - - - - - - - 416673 416674
	Modified or additional components for unshrouded Series 6 pump for APV UPERISER units only							
26	Motor rails	2	-	-	-	-	343937	-
27	Foot, ball, adjustable	4	-	-	-	-	337600	-
28	Locknut, 5/8 in. BSF, hex.	4	-	-	-	-	418660	-
29	Setscrew, 1/2 in. BSW x 1 3/5 in. lg., hex. head	4	-	-	-	-	453370	-
30	Washer, plain, 1/2 in.	4	-	-	-	-	443520	-
31	Body, pump	1	-	-	-	-	205975	-
32	Nameplate	1	-	-	-	-	457842	-
	TOOLS	††						
	Hex. Wrench (Allen key) for stub shaft screws: 3/16 in. A/F for 1 in. dia. shaft 7/32 in. A/F for 1 1/2 in. dia. shaft		414105 -	414105 -	414105 -	414105 414106	414105 414106	- 414106
	Spanner for impeller nut: 1 in. dia shaft 1 1/2 in. dia shaft	1	438986 -	438928 -	438928 -	438928 438919	438928 438919	- -
	Spacer collar (See page 2) 1 in. dia shaft 1 1/2 in. dia shaft	1	347651 -	347651 -	347651 -	347651 347672	347651 347672	- 347672
	Assembly tools for aseptic seal Assembly sleeve to fit seals 1 in. dia shaft 1 1/2 in. dia shaft	1	- -	- -	- -	353320 353329	353320 353329	- -
	Assembly tools for seal faces 1 in. dia shaft 1 1/2 in. dia shaft	1	- -	- -	- -	353319 353328	353319 353328	- -
	O-ring for use with above tool to protect lapped faces (See Page 11 for Code Numbers)							

†† not illustrated

APV Puma Pump Series V & VI (contd)

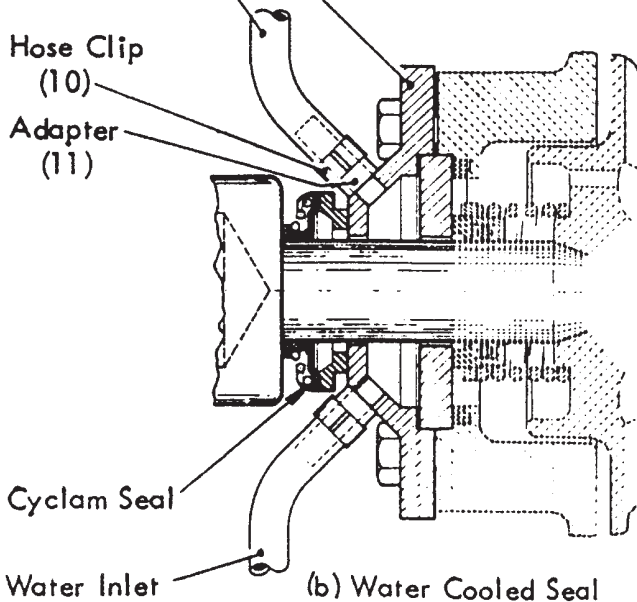
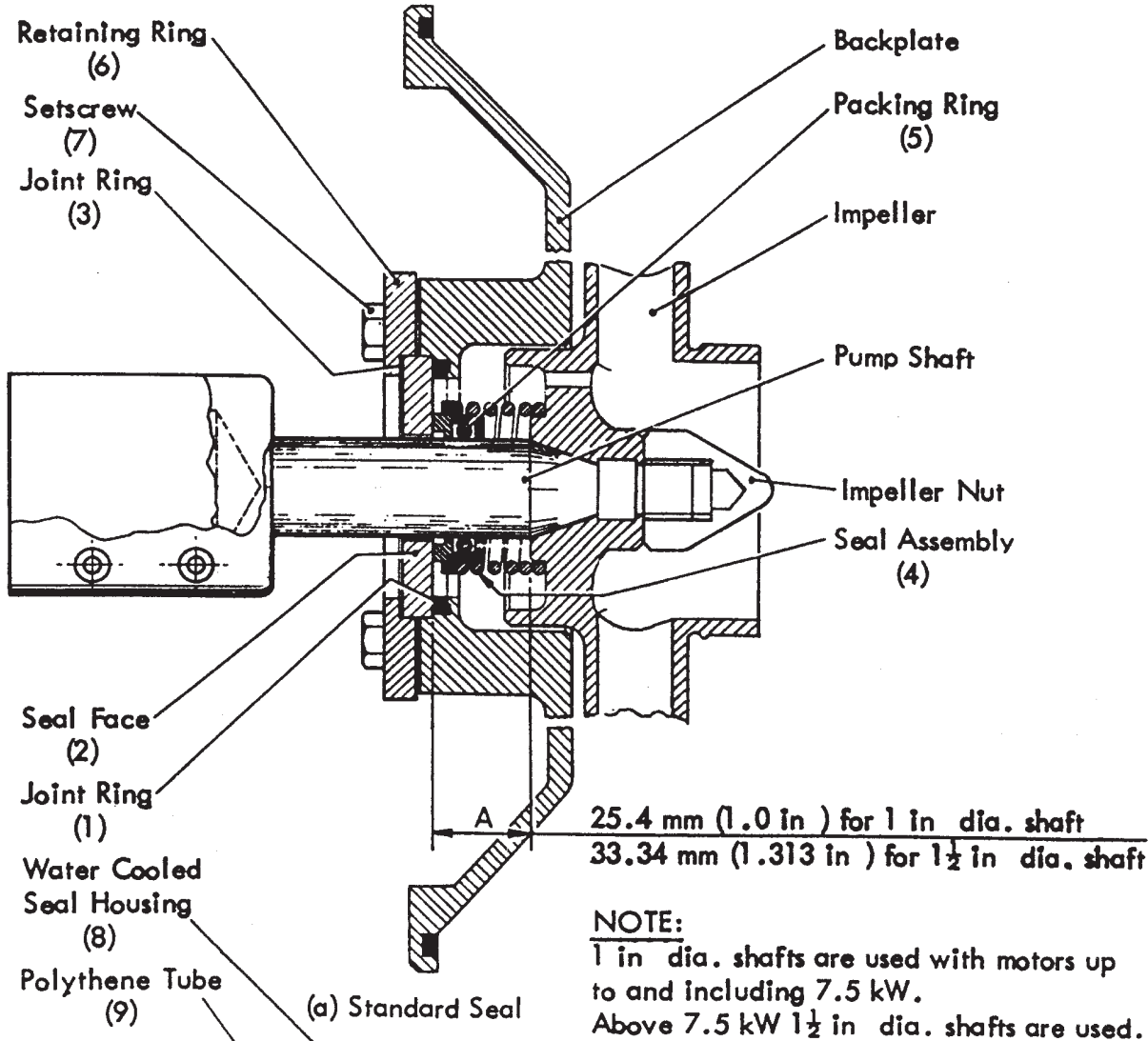

Flexibox Seals





Puma Pump Series V & VI (contd)

PUMA PUMP SERIES V & VI - INCLUDING 1 1/2/ 7 PUMP, SERIES 2								
ITEM	DESCRIPTION	No. off	1 1/2/7	2/2/9	2/2 1/2/9	2/3/9	2/3/11	3/4/11
Page 16	NON-WATER COOLED FLEXIBOX SEAL							
1	Joint, seal face, gasket 1 in. dia shaft 1 1/2 in. dia shaft	1	413812 -	413812 -	413812 -	413812 413997	413812 413997	- 413997
2	Seal face 1 in. dia shaft 1 1/2 in. dia shaft	1	459646 -	459646 -	459646 -	459646 459641	459646 459641	- 459641
3	Joint, retaining ring, gasket 1 in. dia shaft 1 1/2 in. dia shaft	1	444000 -	444000 -	444000 -	444000 413998	444000 413998	- 413998
4	Seal assembly: Flexibox R2540-73R 1 in. dia shaft Flexibox RG1500A-93R 1 1/2 in. dia shaft	1	427840 -	427840 -	427840 -	427840 459642	427840 459642	- 459642
5	'O' ring (packing ring) 1 in. dia shaft 1 1/2 in. dia shaft	1	426753 -	426753 -	426753 -	426753 426509	426753 426509	- 426509
6	Retaining ring, 1 in. dia shaft Retaining ring, 1 1/2 in. dia shaft	1 or 1	344394 -	344394 -	344394 -	344394 343438	344394 343438	- 343438
7	Setscrew, 5/16 in. B.S. hex. head	3	431724	431724	431724	431724	431724	431724
	EXTRA ITEMS REQUIRED FOR WATER-COOLED SEAL							
8	In place of item 6: Housing, 1 in. dia shaft Housing, 1 1/2 in. dia shaft	1 or 1	208836 -	208836 -	208836 -	208836 208859	208836 208859	- 208859
9	Tube, polythene, 3/8 in. o.d. x 18 in. long	2	182615	182615	182615	182615	182615	182615
10	Hose clip	2	406208	406208	406208	406208	406208	406208
11	Adaptor, 3/8 in. o.d. to 1/8 in. B.S.P.	2	353158	353158	353158	353158	353158	353158
12	Seal assembly: Cyclam ADN1B25.47.13PR, 1 in. dia shaft Cyclam ADN1A38.65.18PR, 1 1/2 in. dia shaft		427866 -	427866 -	427866 -	427866 459643	427866 459643	- 459643

APV Puma Pump Series V & VI (contd)

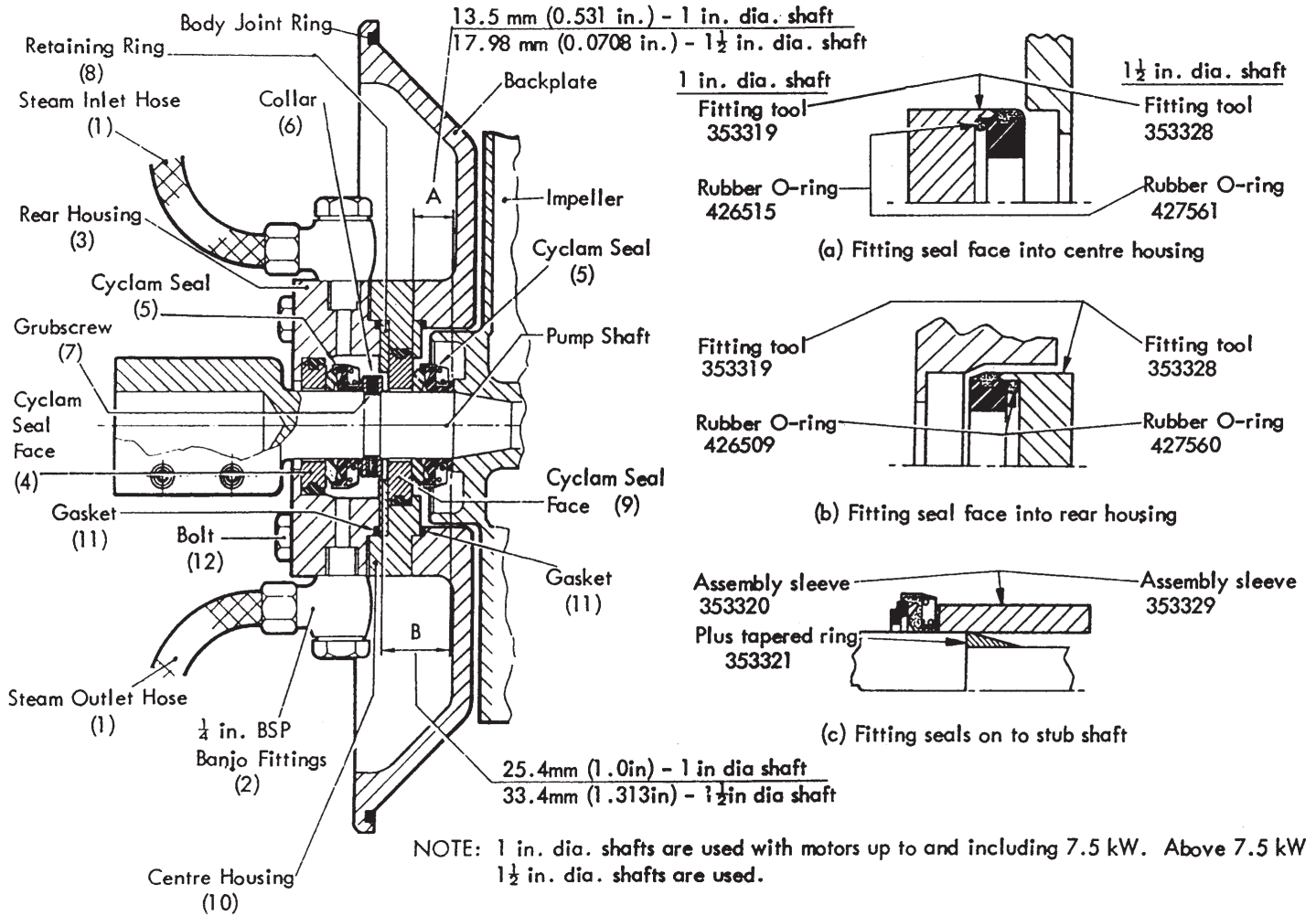

Cyclam Aseptic Seal





Puma Pump Series V & VI (contd)

PUMA PUMP SERIES V & VI - INCLUDING 1 1/2/ 7 PUMP, SERIES 2								
ITEM Page18	DESCRIPTION	No. off	1 1/2/7	2/2/9	2/2 1/2/9	2/3/9	2/3/11	3/4/11
	ASEPTIC SEAL							
1	Hose, steam, 1/4 in. i.d. x 18 in. long	2	-	-	-	410922	410922	-
2	Banjo fitting, 1/4 in. B.S.P.	2	-	-	-	400146	400146	-
3	Rear housing	1						
	1 in. dia shaft		-	-	-	324904	324904	-
	1 1/2 in. dia shaft		-	-	-	324936	324936	-
4	Seal face, steam	1						
	1 in. dia shaft		-	-	-	356067	356067	-
	1 1/2 in. dia shaft		-	-	-	356069	356069	-
5	Seal	2						
	Cyclam ADN14K.25.47.13PR, 1 in. dia shaft		-	-	-	459149	459149	-
	Cyclam ADN14K.38.65.18PR, 1 1/2 in. shaft		-	-	-	459647	459647	-
6	Collar	1						
	1 in. dia shaft		-	-	-	314682	314682	-
	1 1/2 in. dia shaft		-	-	-	314695	314695	-
7	Grubscrew, 2BA x 1/4 in. long	2	-	-	-	434106	434106	-
8	Retaining ring	1						
	1 in. dia shaft		-	-	-	345088	345088	-
	1 1/2 in. dia shaft		-	-	-	355629	355629	-
9	Seal face, product	1						
	1 in. dia shaft		-	-	-	356068	356068	-
	1 1/2 in. dia shaft		-	-	-	356070	356070	-
10	Centre housing	1						
	1 in. dia shaft		-	-	-	324903	324903	-
	1 1/2 in. dia shaft		-	-	-	324935	324935	-
11	Gasket	2						
	1 in. dia shaft		-	-	-	449115	449115	-
	1 1/2 in. dia shaft		-	-	-	449149	449149	-
12	Bolt, 5/16 in. BSF, hex. head	3						
	1 in. dia shaft		-	-	-	403219	403219	-
	1 1/2 in. dia shaft		-	-	-	403223	403223	-
	Spares pack comprising items 4, 9 & 11	1						
	1 in. dia shaft		-	-	-	245279	245279	-
	1 1/2 in. dia shaft		-	-	-	223332	223332	-
	Shaft, stub	1						
	1 in. dia		-	-	-	354344	-	-
	2.2 kW motor		-	-	-	354345	354345	-
	4.0 kW motor		-	-	-	354346	354346	-
	5.5 & 7.5 kW motor		-	-	-	-	354340	-
	1 1/2 in. dia. for		-	-	-	-	-	-