

Rannie 75 / Gaulin 75

Introduction

The Rannie 75 / Gaulin 75 homogeniser, a positive displacement triplex, reciprocating plunger pump, is fitted with an application-specific homogenising valve assembly: single-stage with hydraulic actuation.

The Rannie 75 / Gaulin 75 homogeniser incorporates a durable slow-speed power end that reduces vibration and noise. Easy access to the hydraulic actuation system, lubrication oil and other auxiliary systems simplifies maintenance saving time and money. Liquid end options include a three-piece valve housing (Rannie) and a mono-block design (Gaulin) (ball and poppet style).

Design features of both the Rannie and Gaulin simplify routine maintenance. Materials for plungers, packings, pump valves, valve seats and seals are custom-selected for your application. APV engineers will work with you to optimise the configuration for your specific application.



STANDARD OPTIONS

- Two-stage hydraulic valve actuation (HVA)
- Single-stage automatic hydraulic system (AHS)
- Two-stage automatic hydraulic system (AHS)
- Pulsation dampener(s) on inlet and outlet
- Aseptic cylinder design
- High-pressure outlet
- Inlet pressure gauge
- Plunger lubrication control package
- Micro-Gap homogenising valve
- Tungsten carbide homogenising valve
- Square plunger seals and ceramic plungers (Rannie valve housing only)
- External cooling fan/main motor
- Motor starter
- Control cabinet, stainless steel
- Thermostat/oil temperature

SPECIAL OPTIONS

- Acid-proof cylinder (Gaulin valve housing only)
- Ceramic plungers with U- or V-rings
- Explosion-proof design
- Electropolished wettables
- High-temperature design
- Flow switch - power end cooling
- UFO -Unit for Filtration of Oil



RANNIE THREE-PIECE
VALVE HOUSING



GAULIN MONO-BLOCK
DESIGN

RANNIE/THREE-PIECE VALVE HOUSING POPPET AND BALL TYPE VALVES

TYPE	U.S. MAX. CAP./MAX. PRESS.		METRIC MAX.CAP./MAX. PRESS	
	GPH	PSI	LPH	BAR
75.95	3500	2000	13500	140
70.95	3100	2500	11800	170
65.95	2640	3000	1000	200
45.95	1320	5800	5000	400
25.95	265	17400	1000	1200
22.95	210	21750	800	1500

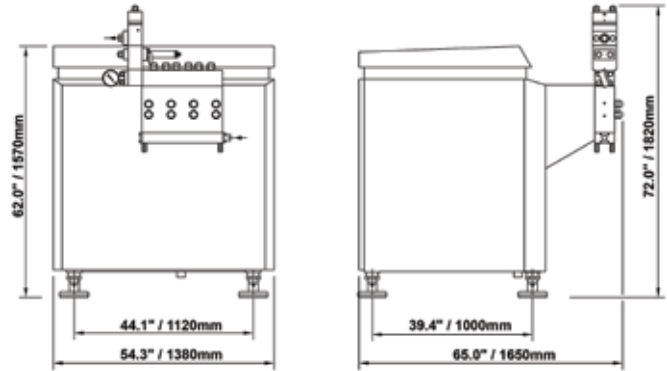

GAULIN/MONO-BLOCK DESIGN

TYPE	U.S. MAX. CAP./MAX. PRESS.		METRIC MAX.CAP./MAX. PRESS	
	GPH	PSI	LPH	BAR
POPPET TYPE VALVES				
2.0	3550	2000	13500	140
2.5	3100	2500	11800	170
3.0	2640	3000	10000	200
5.8	1320	5800	4000	400
BALL TYPE VALVES				
2.0	3460	2000	13100	140
2.5	3010	2500	11400	170
3.0	2640	3000	1000	200
5.8	1240	5800	4700	400

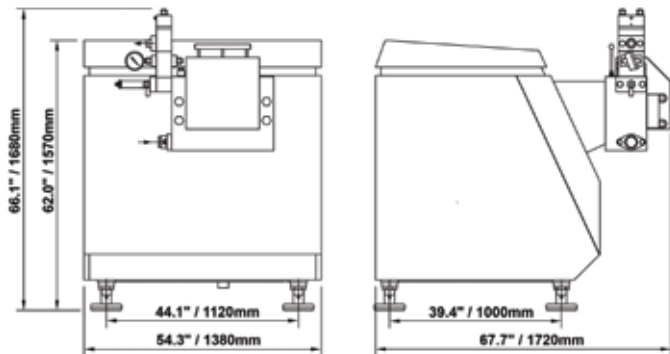

DIMENSIONS (SINGLE STAGE)

DIMENSIONS PACKED IN A CRATE LXWXH (IN.)	DIMENSIONS PACKED IN A CRATE LXWXH (CM)	CUBIC MEASURE M3	GROSS WEIGHT IN A CRATE INCL. MOTOR
75.6 X 66 X 84.4	189 X 165 X 211	6.6	5,952 LB./2,700 KG

SPX

SPX Flow Technology, Oestmarken 7, DK 2860 Soeborg

+45 70 278 222 F: +45 70 278 223

For more information about our worldwide locations, approvals, certifications, and local representatives, please visit www.spx.com.

SPX Corporation reserves the right to incorporate our latest design and material changes without notice or obligation. Design features, materials of construction and dimensional data, as described in this bulletin, are provided for your information only and should not be relied upon unless confirmed in writing.

The green ">" is a trademark of SPX Corporation, Inc.

APV-3169-GB Version: 05/2012 Issued: 11/2012 COPYRIGHT © 2011, 2012 SPX Corporation